

OPERATION MANUAL

14" Rigging Sheave

Manufactured by Wireline Technologies, Inc.

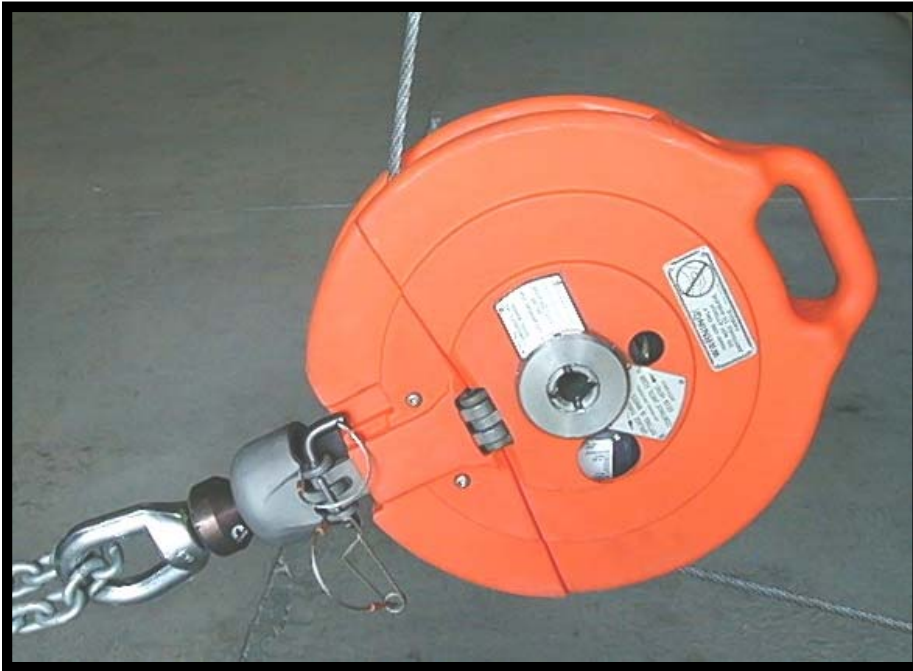

Serial Number _____

Introduction

This manual explains the use and care of 14” rigging sheaves manufactured by Wireline Technologies, Inc. The sheave is available in two models. The original model has shielded bearings and is identified by an orange cover. The sealed bearing model is identified by a yellow cover. Each is available in two configurations. The no-shroud configuration, shown in figure 1, will allow a rope socket or “torpedo” to pass over the wheel. The half-shroud configuration, shown in figure 2, has a cable shroud covering part of the wheel to aid in containing the line in the wheel groove. Please read and become familiar with all of the information in this manual before using this equipment.



No-Shroud (Optional)
Figure 1



Half-Shroud (Standard)
Figure 2

Warnings

- Read entire manual before operating this equipment.
- If proper procedures are not followed, loads may disengage.
- A falling load can cause serious injury or death.
- Never use this product for hoisting personnel.
- Always anchor or hang the sheave via the clevis, never by way of the cover or any ancillary equipment.
- Never apply more force than the Safe Working Load (SWL) listed on the affixed tag.
- The listed Safe Working Load is for the sheave assembly; the safe line tension will be less.
- Attachment to other equipment with lower SWL will reduce the allowable load.
- Always use a hand guard when the sheave is used around personnel.
- Always make sure the sheaves are properly maintained and properly rigged.

Safe Working Load

The rated safe working load (SWL) for a WTI 14" sheave is 15,000 lbs. (6,800 kg.), with the exception of those manufactured for Schlumberger. These sheaves, as directed by Schlumberger, have a safe working load of 10,000 lbs. (4,530 kg.). The allowable line pull will depend upon both the SWL and the angle the line is deflected. If the sheave is used as a top sheave, it deflects the line 180°, see figure 3. If the sheave is used as a bottom sheave, it deflects the line 90°, see figure 4. Never exceed the SWL, unless special precautions are taken in accordance with your company's policy. These precautions should include, but are not limited to, clearing the rig floor of all personnel. If the SWL is exceeded, the sheave should be re-certified before it can safely be placed back in service.

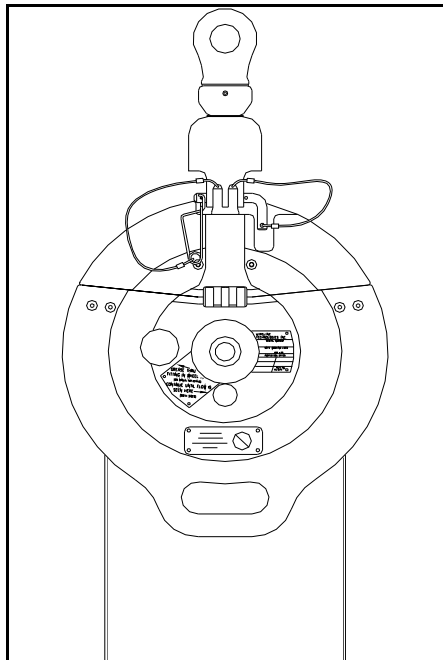

Top Sheave
Max. line tension
7,5000 lbs. (3,400 kg)

Schlumberger Limit
Max. line tension
5,000 lbs (2,260 kg)

Safe Line Tension for
180-Degree Deflection
Figure 3

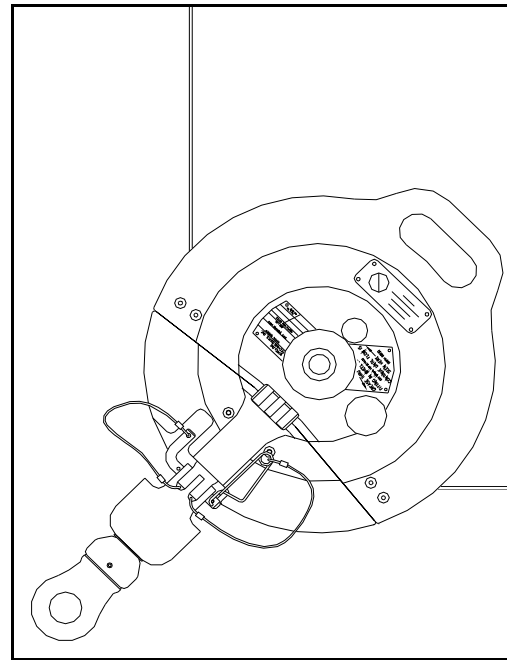

Bottom Sheave
Max. line tension
10,600 lbs. (4,800 kg)

Schlumberger Limit
Max. line tension
7,070 lbs (3,200 kg)

Safe Line Tension for
90-Degree Deflection
Figure 4

Clevis Options

Five clevis swivel assembly options for suspending/anchoring the sheave are available: These options are shown in figures 5 – 9 below. The Clevis-Eye has an opening about 2.5" X 3.3" for a chain or sling. The opening width of the Clevis -AWS is 1 3/4" with a hole for a 1" pin. The opening width of the Clevis -HLS is 1 1/4" with a hole for a 1" pin. The opening width of the Clevis-SJ is 7/8" with a hole for a 1 1/2" pin. The shackle clevis has about the same opening as the Clevis-Eye.

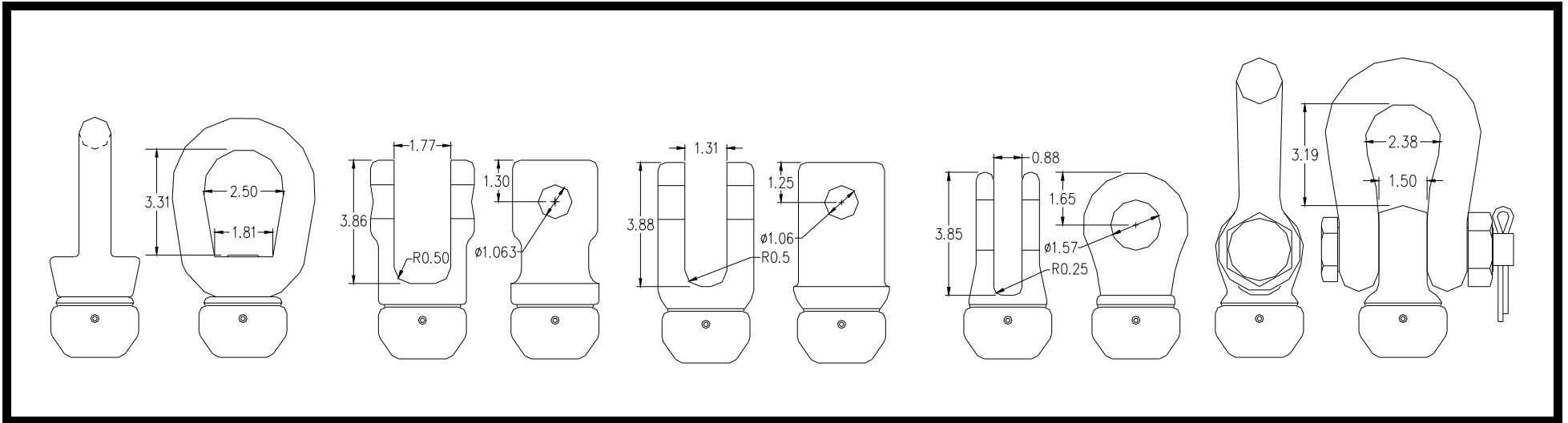

Clevis-Eye
Part # RS-1075A
Figure 5

Clevis-AWS
Part # RS-1252A
Figure 6

Clevis-HLS
Part # RS-1552A
Figure 7

Clevis-SJ
Part # RS-1052A
Figure 8

Clevis-Shackle
Part # RS-1152A
Figure 9

Loading

The numbers listed refer to figure 14 and table 1 on pages 7 and 8.

1. Remove gate clip (19).
2. Remove the gate pin (20).
3. Open the loading gate (6 or 9).
4. Load line into groove of wheel (15). See figure 10. Do NOT load the line on top of the shroud that covers the wheel.
5. Close the loading gate, aligning its holes with the holes in the frame (23).
6. Install the gate pin through the holes.
7. Squeeze the gate clip and insert it through the hole in the end of the gate pin.
8. Release the clip and rotate it against the cover. Make sure the clip closes completely. See figure 11.



Properly Loaded Line
Figure 10



Properly Closed Gate
Figure 11

Daily Inspection Checklist

Verify the following. If any discrepancies are noted, remove the sheave from service until repairs are completed. Numbers listed refer to figure 14 and table 1 on pages 7 and 8.

- ❑ All structural components (6 or 9,15,20,23,32,40,52,59,62,64) are not bent, cracked, or otherwise damaged.
- ❑ Loading gate (6 or 9) hinges freely through the fingers in the frame (23).
- ❑ Gate pin (20) can be easily inserted through the holes in the frame (23) and is securely attached with a lanyard (22).
- ❑ Manufacturing tag (17) and safe working load tag (42) are in place and are readable.
- ❑ Inspection tag (29) is in place on the cover and stamped with an inspection date no greater than one year old.
- ❑ Spiral pins (34) are in place and securely retain the axle nuts (33,35) on the axle (32).
- ❑ Wheel (15) rotates freely and smoothly, check for any grinding or sticking, indicating damaged bearings.
- ❑ Gate pin (20) and gate clip (19) are undamaged, lock positively, and are securely attached with lanyards (22).
- ❑ Clevis (64) pivots freely and does not have excessive slop (more than 1/8”).
- ❑ Both setscrews (58) are in place and the clevis (64) is secure in the clevis housing (59).
- ❑ Cotter pin (51) is securely retaining the clevis nut (52).

Preventative Maintenance

WTI suggests the following service. Numbers listed refer to figure 14 and table 1 (pg 7-8).

- ❑ The wheel bearings (11) of the orange sheaves are shielded and should be re-greased at least once a month, more often in wet or dusty environments. Always re-grease after pressure washing. Grease is injected through a fitting in the wheel, accessed through a hole in the cover. See figure 12. Use lithium based No.2 EPHT grease, such as Conoco's Tacna® RX. Make sure enough grease is used to extrude past both front and rear shields (10). The smaller holes on each side of the cover are for checking this.
- ❑ The wheel bearings of the yellow sheaves are sealed and only need annual re-packing. This service can be performed at the same time as the annual recertification. See page 6.
- ❑ Monthly, squirt some light machine oil on the hinge pin (between the fingers of the gate frame (40) and the loading gate (6 or 9), and onto the gate pin (20).



Greasing Holes
Figure 12

Recertification and Repairs

WTI highly recommends yearly recertification of all rigging sheaves, hanger bars, and clevis pins. Most wireline servicing companies mandate annual recertifications so this should not be overlooked. A tag on the front of the cover, shown in figure 13, provides a visible place to stamp certification dates. When a new sheave is placed into service, stamp the current date into this tag. When the date becomes a year old, the sheave should be re-certified. Each time the sheave is re-certified a new date will be stamped in this tag. Upon completion of a repair or recertification, note the information in the log in the back of this manual. Re-certification involves the following:

1. Proof testing.
2. Disassembly.
3. Cleaning
4. NDT inspection of all of the load-bearing components.
5. Replacement or repair of any damaged or worn components.
6. Updating components for safety and easier use.
7. Packing the bearings with grease.
8. Re-assembly.
9. Pre-loading the bearings.
10. Documentation of all changes.
11. Final Inspection.
12. Issuance of a new certification.



Inspection Tag
Figure 13

Recertification and/or repairs can be done one of three ways.

- Send the sheave to Wireline Technologies, Inc. Please call to make arrangements.
- Send the sheave to an authorized service center. Call to determine the nearest location.
- Determine if your company will allow recertification on site. If so, WTI can supply you with the training and documents needed.

Call Wireline Technologies Inc. (800) 743-2831. Use the drawings in figure 15 on page 7 to identify parts. The numbers in the circles correspond to the item numbers in table 1 on page 8.

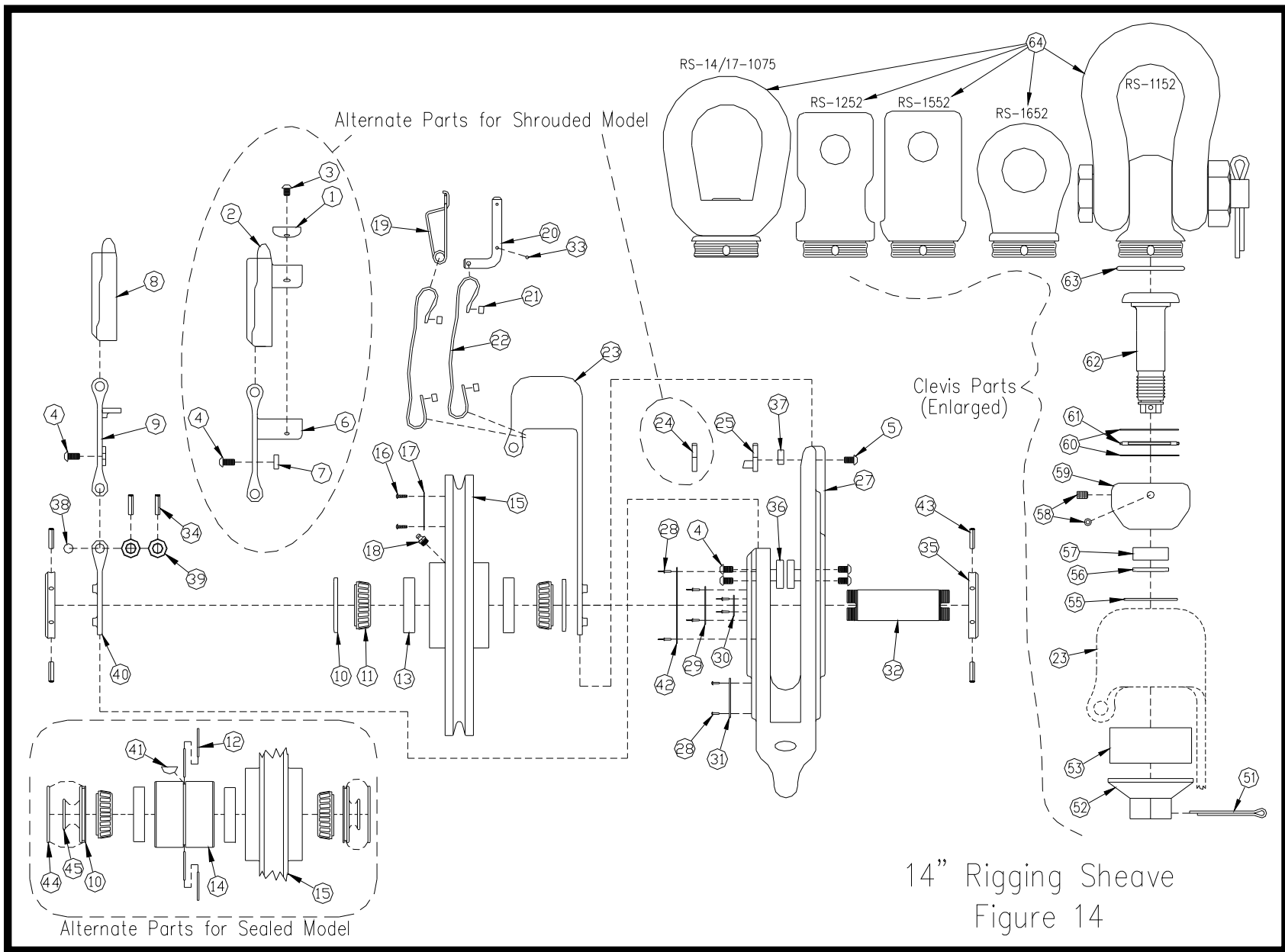

Item	Part Number	Description	Qty. Shrd.	Qty. No-S	Material	Item	Part Number	Description	Qty. Shrd.	Qty. No-S	Material
1	RS-1180	Shroud Warning Label	1		Al	or	RS-26-1079	Baker Atlas Inspection Label	1	1	Al
2	RS-14-1222-O	Gate Cover - 14", Shrouded	1		X-link Orange	30	RS-14-1280	Grease Warning Label - 14"	1	1	Al
or	RS-14-1222-Y	Gate Cover - 14" Sealed, Shrouded	1		X-link Yellow	31	RS-1080	Handle Warning Label	1	1	Al
3	RS-1066	Button Head Screw 5/16-18 X 3/8"	2		18-8 S/S	32	RS-1109	Axle Shaft	1	1	17-4PH S/S
4	RS-1065	Button Head Screw 5/16-18 X 1/2"	10	10	18-8 S/S	33	RS-1316	Spiral Pin 5/32" X 3/4"	1	1	420 S/S
5	RS-1073	Button Head Screw 5/16-18 X 5/8"	2	2	18-8 S/S	34	RS-1172	Spiral Pin 1/4" X 1"	2	2	420 S/S
6	RS-14-1007-H	Loading Gate - 14", Half Shroud	1		17-4PH S/S	35	RS-1011A	Axle Nut - Adjustable	2	2	303 S/S
7	RS-1060	Front Plate	1	1	Anod. Al	36	RS-1062	Stand-Off Pad	4	4	Anod. Al
8	RS-14-1322-O	Gate Cover - 14", No Shroud		1	X-link Orange	37	RS-14/17-1261	Plug for Rear Plates	1	1	Al
or	RS-14-1322-Y	Gate Cover - 14" Sealed, No Shroud		1	X-link Yellow	38	RS-1105	Hinge Pin	1	1	17-4PH S/S
9	RS-14-1007-N	Loading Gate - 14", No Shroud		1	17-4PH S/S	39	RS-1006	Collar	2	2	303 S/S
10	RS-1029	Nilos Grease Ring - 14"/17"	2	2	Galv. Steel	40	RS-14-1024	Gate Frame - 14"	1	1	17-4PH S/S
or	RS-14/17-1067S	O-ring Seat - 14"/17"	2	2	H Anod. Al	41	RS-1010	Woodruff Key #807	1	1	316 S/S
11	RS-1084	Bearing Cone - 14"/17"	2	2	Alloy Steel	42	RS-14-1380	SWL Label (not on BA)	1	1	Laminar
12	RS-14/17-1012S	Retaining Strip - 14"/17"	4	4	Ultem 1000	43	RS-1272	Spiral Pin 1/4" X 1 1/4"	4	4	420 S/S
13	RS-1083	Bearing Cup - 14"/17"	2	2	Alloy Steel	44	RS-14/17-1048	O-ring - 14"/17", Outer	2	2	Buna N
14	RS-14/17-1045S	Wheel Hub - 14"/17" Sealed	1	1	H. Anod. Al	45	RS-14/17-1049	O-ring - 14"/17", Inner	2	2	Buna N
15	RS-14-1008-XX	Sheave Wheel - 14"	1	1	Composite						
or	RS-14-1008S-XX	Sheave Wheel - 14" Sealed (XX = dash number for groove)	1	1	Composite	51	RS-1378	Cotter Pin 3/16" X 2"	1	1	316 S/S
16	RS-1071	Drive Screw #6 X 3/8"	4	4	18-8 S/S	52	RS-1055	Clevis Nut	1	1	17-4PH S/S
17	RS-14-1077	Manufacturing Label - 14"	1	1	Laminar	53	RS-1218	Shock Cushion - 1 1/4" Thick	1	1	Buna N
18	RS-1039	Grease Fitting 1/8" NPT (Not on sealed model)	1	1	Zinc Steel	55	RS-1020	Clevis Washer	1	1	Nylon
19	RS-1416	Gate Clip	1	1	302 S/S	56	RS-1057	Clevis Bearing Seal	1	1	Buna N
20	RS-1216	Gate Pin	1	1	17-4PH S/S	57	RS-1056	Clevis Bearing	1	1	Alloy Steel
21	RS-1032	Ferrule	4	4	Copper	58	RS-1068	Set Screw - Cup 1/4"-20 X 3/8"	2	2	Zinc Alloy
22	RS-1031	Lanyard	2	2	18-8 S/S	59	RS-1053	Clevis Housing	1	1	17-4PH S/S
23	RS-14-1028	Frame - 14"	1	1	17-4PH S/S	60	RS-1058	Thrust Washer	2	2	Alloy Steel
24	RS-1061	Rear Plate	1		Anod. Al	61	RS-1059	Thrust Bearing	1	1	Alloy Steel
25	RS-1161	Rear Plate W/ Tab (No Shroud)		1	Anod. Al	62	RS-1154	Clevis Shaft	1	1	17-4PH S/S
27	RS-14-1122-O	Frame Cover - 14"	1	1	X-link Orange	63	RS-1098	O-Ring	1	1	Viton
or	RS-14-1122-Y	Frame Cover - 14" Sealed	1	1	X-link Yellow	64	RS-14/17-1075	Clevis - EYE	1	1	Weldment
28	RS-1090	Blind Rivet 1/8" X 1/2"	12	12	Al	or	RS-1252	Clevis - AWS	1	1	17-4PH S/S
29	RS-1179	WTI Inspection Label	1	1	Al	or	RS-1552	Clevis - HLS	1	1	17-4PH S/S
						or	RS-1652	Clevis - SJ	1	1	17-4PH S/S
						or	RS-1152	Clevis - Shackle	1	1	Assembly

Table 1. Bill of Materials

Clevis Pin

Two pins are approved for attachment to a clevis. Clevis Pin Kit - SJ, shown in figure 15, is 1.5” in diameter and is to be used with Clevis-SJ. Clevis Pin Kit, shown in figure 16, is 1” in diameter and is to be used with Clevis-AWS or Clevis-HLS. Both of these pins are manufactured from precipitation hardened, high strength, stainless steel alloy. These clevis pins are load bearing and should be re-certified annually with the rigging sheave.

Instructions for Use

1. Insert the pin through the clevis and the hanger bar or chain to be attached.
2. Thread the nut onto the end of the pin.
3. Install the safety clip through the hole in the end of the pin and lock it in place.

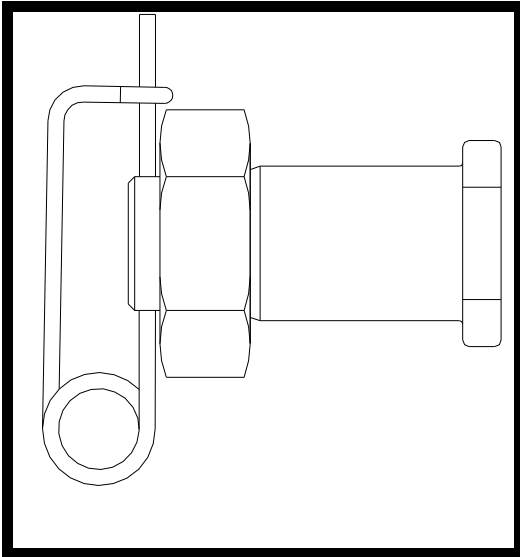

Clevis Pin Kit – SJ
Part # RS-1699
Figure 15

Clevis Pin Kit
Part # RS-1899
Figure 16

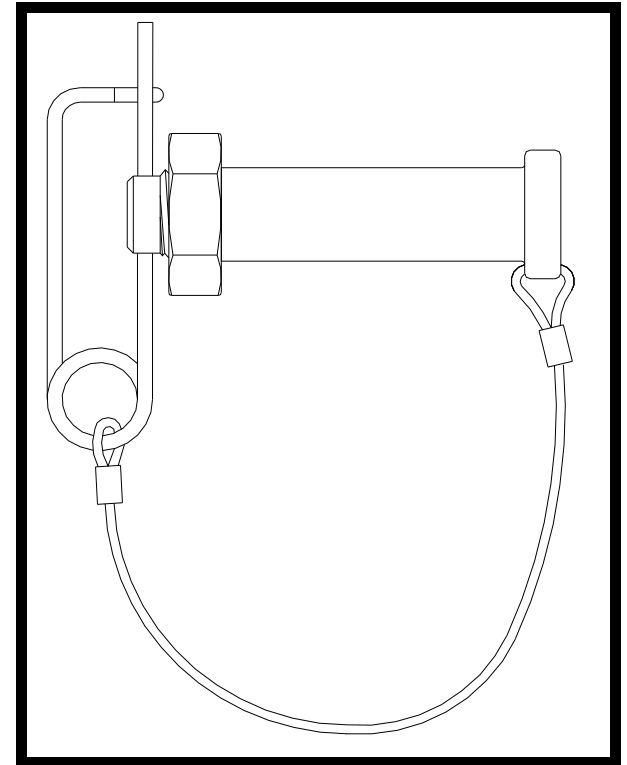

Hanger Bar

The hanger bar hangs from a crown block or elevator and provides a place to attach the rigging sheave. See figure 17. For use with Clevis-SJ, order Part # SH-100, hole (D) is 1.56". For use with Clevis-AWS or Clevis-HLS, order Part # SH-200, hole (D) is 1.06". The hanger bar bears the same loads as the rigging sheave and should be re-certified annually.

Instructions for Use

1. Install the hanger bar in a safe position.
2. Line the holes in the clevis up with the hole in the end of the hanger bar.
3. Insert an approved pin, shown on page 9, through the holes.
4. Properly lock the pin in place.

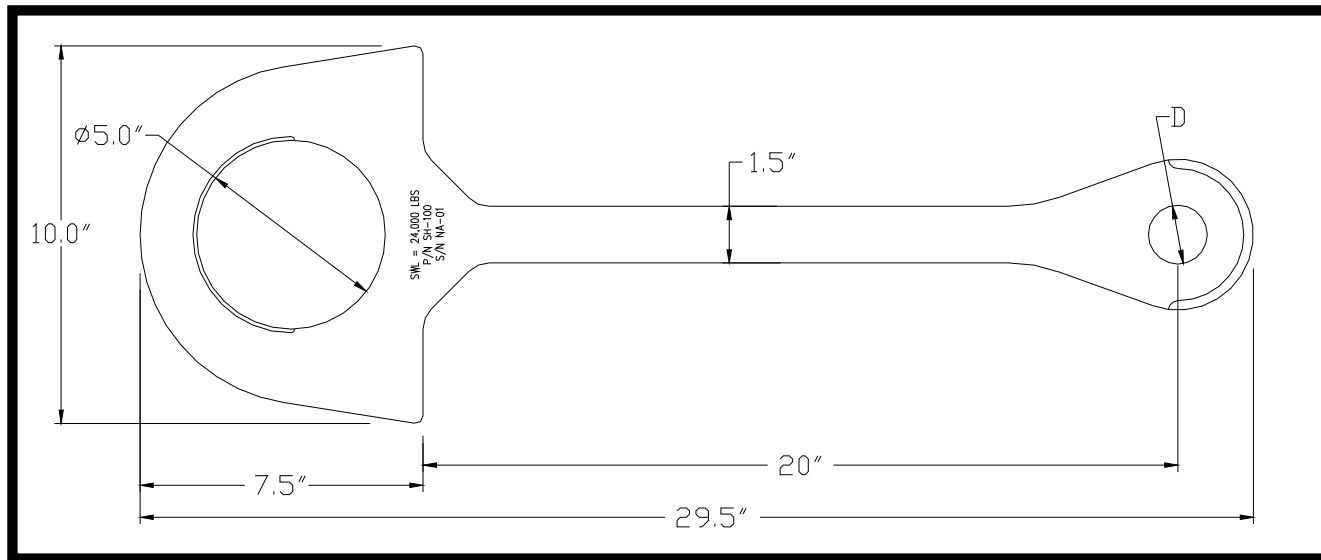

Hanger Bar, Figure 17

Hand Guard

Perhaps the most important accessory to a rigging sheave is the hand guard. The hand guard helps prevent accidental entanglement of personnel into the sheave wheel. It is also very helpful at directing the line into the wheel groove to prevent jumping. See figure 18. A hole in the bushing allows the line to pass, but larger objects such as hands and clothing are stopped. The hand guard features split bushings and slotted blocks so it installs quickly and can be left in place when the sheave is not in use. See figure 19 on page 12.

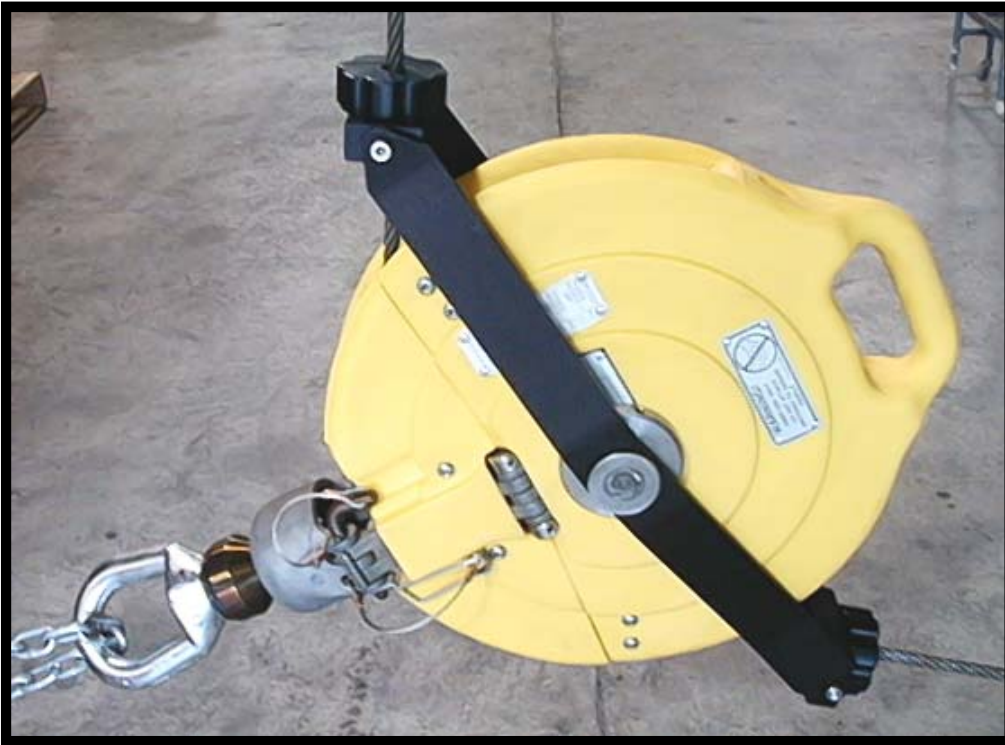

Hand Guard, Part # HG-14/17-100
Figure 18

Instructions for Use

1. Remove the split bushings by unthreading them from the blocks.
2. Install the arms on either side of the sheave so the holes in the hinges line up with the holes in the axle shaft.
3. Insert the pivot pin through one of the hinges, then the axle, and then the other hinge.
4. Thread the slotted nut onto the end of the pivot pin.
5. Install the cotter pin through the hole in the pivot pin then spread the ends to secure. See figure 20 on page 12.
6. Pull the bushing apart then re-assemble them around the wireline. See figure 19 on page 12.
7. Thread the bushings back into the blocks.

Maintenance

- ◇ Replace the split bushings if the holes wear close to the threads.
- ◇ Lubricate the hinges with light machine oil to keep them moving freely.

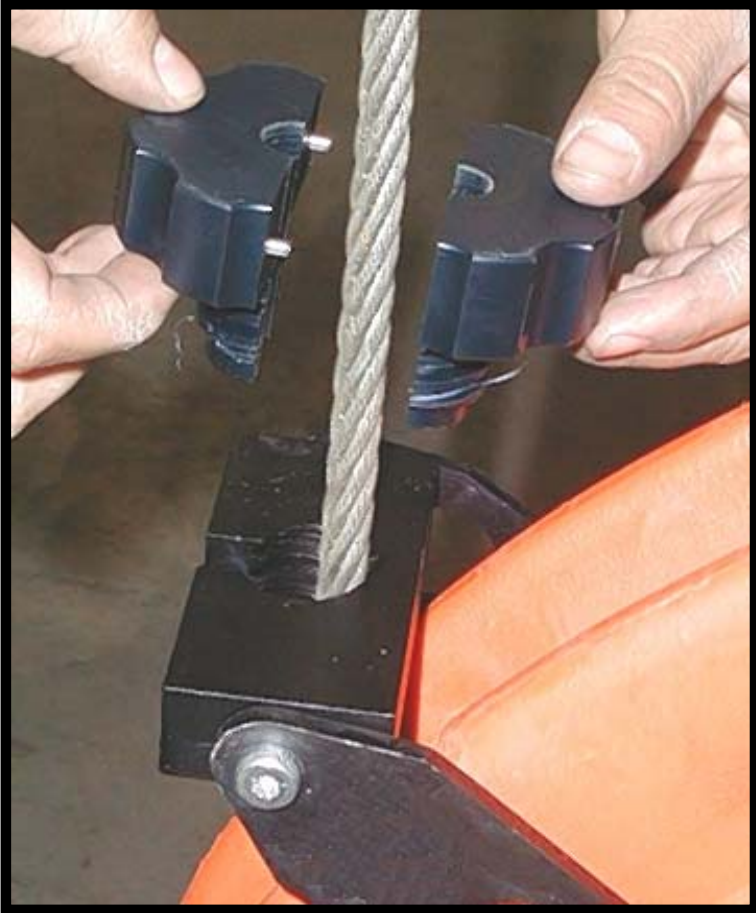

Split Bushing
Figure 19



Properly Locked Pivot Pin
Figure 20

Line Retainer

The line retainer is used on a top sheave to ensure the wireline remains in the groove of the sheave. Figure 21 shows a line retainer in use. Figure 22 shows a close-up of retained line being guided back into the sheave.

Instructions for Use

1. Install the line retainer around the sheave so the holes line up with the hole in the axle shaft and the pins fit on either side of the frame. See figure 23.
2. Insert the pivot pin through the holes and out the other side of the line retainer.
3. Thread the slotted nut onto the end of the pivot pin.
4. Install the cotter pin through the hole in the pivot pin then spread the ends to secure. See figure 20 on page 12.



Close-up of
Retained Line,
Figure 22

Warning

Never attach anything to the line retainer. It is not designed to hold loads.



Line Retainer, Part # LR-14-100, Figure 21



Pins of Line Retainer, Figure 23

Floor Stand

The floor stand is used to keep the sheave upright and in position when the line is slack. Figure 24 shows a sheave mounted in a floor stand. A floor stand can be used with a hand guard. Because the floor stand is open on one side, the line can be loaded into the sheave after the floor stand has been attached. See figure 25.



Floor Stand, Part # FS-100
(Shown with Hand Guard)
Figure 24



Floor Stand
(Open Side)
Figure 25

Instructions for Use

1. Slide the sheave onto the protruding pin of the floor stand.
2. Place the collar on the end of the pin.
3. Align the holes in the collar with the hole in the end of the pin.
4. Install the safety clip through the holes and lock it in place.

Rig-up Yoke

The rig-up yoke is used to lift the rigging sheave into position or to stabilize the sheave when in use. Figure 26 shows a yoke being used to stabilize a rigging sheave. A rig-up yoke can be used with or without a hand guard or a line retainer.

Instructions for Use

1. Install the yoke on either side of the sheave so the holes line up with the hole in the axle shaft. When used with a hand guard or line retainer, position the rig-up yoke on the outside.
2. Insert the pivot pin through the holes and out the other side of the yoke.
3. Thread the slotted nut onto the end of the pivot pin.
4. Install the cotter pin through the hole in the pivot pin then spread the ends to secure. See figure 20 on page 12.
5. Secure the yoke to hold the sheave in the desired position.

Warnings

- Never use the rig-up yoke as a substitute for the clevis. It is not designed to hold loads.
- Never pull the sheave to the side with the rig-up yoke. Always keep it aligned with the wireline.
- Never pull on the rig-up yoke harder than is required to hold the sheave in position.



Rig-Up Yoke, Part # RYA-100, Figure 26

Storage Rack

A storage rack, sometimes called a truck stand, is a convenient device to hold a sheave secure while traveling. See figure 27.

Instructions for Use

1. Position the clevis under the loop.
2. Rest the axle nuts of the sheave in the V shaped supports.
3. Install the pin through the supports and the center of the sheave.
4. Install the safety clip through the hole in the end of the pin and lock it in place.

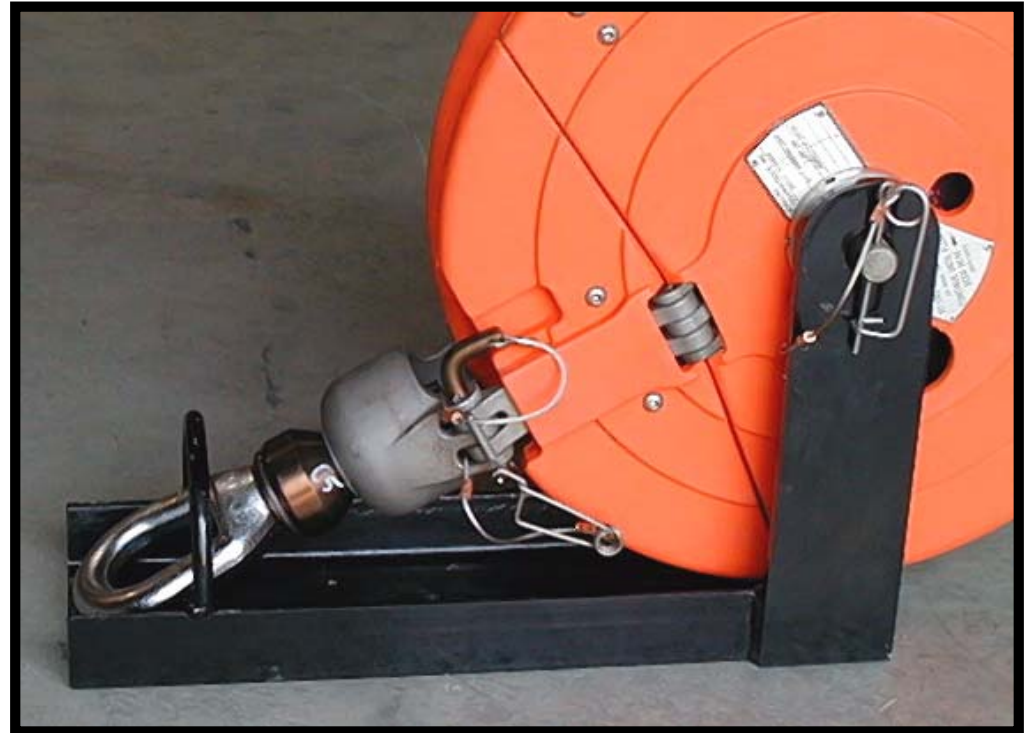

Storage Rack, Part # TS-14/17-100
Figure 27

Date	Recert	Repair	Performed by:	Notes
	<input type="checkbox"/>	<input type="checkbox"/>		
	<input type="checkbox"/>	<input type="checkbox"/>		
	<input type="checkbox"/>	<input type="checkbox"/>		
	<input type="checkbox"/>	<input type="checkbox"/>		
	<input type="checkbox"/>	<input type="checkbox"/>		
	<input type="checkbox"/>	<input type="checkbox"/>		
	<input type="checkbox"/>	<input type="checkbox"/>		
	<input type="checkbox"/>	<input type="checkbox"/>		
	<input type="checkbox"/>	<input type="checkbox"/>		
	<input type="checkbox"/>	<input type="checkbox"/>		

Warranty

For a period of one year from the date of purchase, Wireline Technologies, Inc., will repair or replace, at its option, any 14” rigging sheave of its manufacture that fails because of a defect in materials or manufacture, or which fails to conform to any implied warranty not excluded herein. This warranty does not cover damages caused by abuse, misuse, neglect, or overloading; and does not cover any incidental damages caused by a failure of this product.

EC Declaration of Conformity

The following equipment:

P/N- _____

S/N- _____

Date- _____

Complies with the essential requirements of The European Union
Machinery Directive 98/37/EC.



George Vent (V.P. Quality)

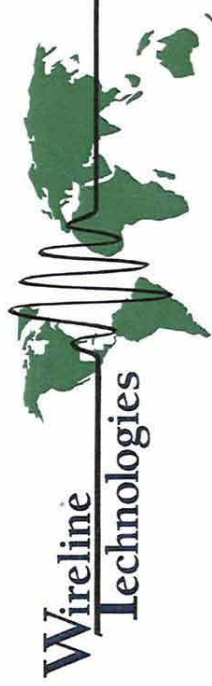

2140 North Redwood Road, #60
Salt Lake City, UT 84116 – USA

www.wtisheave.com

(800) 743-2831